

精密鎖定螺帽 滾珠螺桿、精密主軸、傳動機構專用

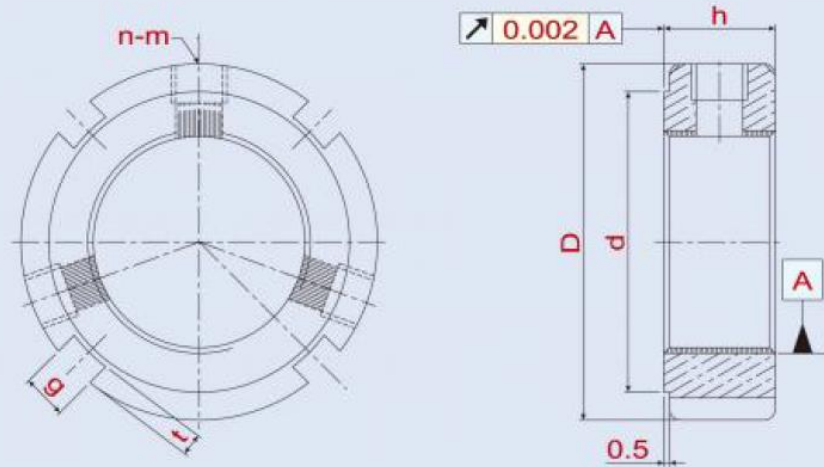

YSR

Thread	D	h	g	t	d	n - m	MAX. Nm
YSR M6 x 0.5	16	8	3	2	11	2 - M4	3.5
YSR M8 x 0.75	16	8	3	2	11	2 - M4	3.5
YSR M10 x 0.75	18	8	3	2	13	2 - M4	3.5
YSR M10 x 1	18	8	3	2	13	2 - M4	3.5
YSR M12 x 1	20	8	3	2	15	2 - M4	3.5
YSR M12 x 1.25	20	8	3	2	15	2 - M4	3.5
YSR M14 x 1.5	25	8	3	2	20	2 - M4	3.5
YSR M15 x 1	25	8	3	2	20	2 - M4	3.5
YSR M16 x 1.5	28	10	4	2	23	2 - M5	4.5
YSR M17 x 1	28	10	4	2	23	2 - M5	4.5
YSR M18 x 1.5	30	10	4	2	25	2 - M5	4.5
YSR M20 x 1	32	10	4	2	27	3 - M5	4.5
YSR M20 x 1.5	32	10	4	2	27	3 - M5	4.5
YSR M22 x 1.5	35	10	4	2	30	3 - M5	4.5
YSR M24 x 1.5	38	12	5	2	33	3 - M6	8.0
YSR M25 x 1.5	38	12	5	2	33	3 - M6	8.0
YSR M27 x 1.5	42	12	5	2	37	3 - M6	8.0
YSR M30 x 1.5	45	12	5	2	40	3 - M6	8.0
YSR M33 x 1.5	52	12	5	2	45	3 - M6	8.0
YSR M35 x 1.5	52	12	5	2	47	3 - M6	8.0
YSR M36 x 1.5	55	14	6	2.5	49	3 - M6	8.0
YSR M39 x 1.5	58	14	6	2.5	52	3 - M6	8.0
YSR M40 x 1.5	58	14	6	2.5	52	3 - M6	8.0
YSR M42 x 1.5	62	14	6	2.5	56	3 - M6	8.0
YSR M45 x 1.5	65	14	6	2.5	59	3 - M6	8.0
YSR M48 x 1.5	68	14	6	2.5	62	3 - M6	8.0
YSR M50 x 1.5	70	14	6	2.5	64	3 - M8	18.0
YSR M52 x 1.5	73	16	7	3	66	3 - M8	18.0
YSR M55 x 1.5	75	16	7	3	68	3 - M8	18.0
YSR M55 x 2	75	16	7	3	68	3 - M8	18.0
YSR M56 x 2	77	16	7	3	70	3 - M8	18.0
YSR M60 x 2	80	16	7	3	73	3 - M8	18.0
YSR M64 x 2	85	16	7	3	78	3 - M8	18.0
YSR M65 x 2	85	16	7	3	78	3 - M8	18.0
YSR M68 x 2	92	18	8	3.5	84	3 - M8	18.0
YSR M70 x 2	92	18	8	3.5	84	3 - M8	18.0

## YSR 徑向鎖定

YSR鎖定方式為徑向三點式鎖定，其厚度相較其他產品為薄，適用於螺帽厚度空間受到限制，無法使用其它產品之情況。

- 材 質：SCM440(42CrMo4)調質
- 硬 度：HRC 28° ~ 32°
- 螺紋精度：ISO 4H精密研磨
- 平面偏擺：M6 ~ 200 : 0.002mm
- 螺紋精度：ISO 4H精密車削
- 平面偏擺：M6 ~ 200 : 0.005mm
- 平面偏擺：M210 ~ 300 : 0.007mm



YSR

Thread	D	h	g	t	d	n - m	MAX. Nm
YSR M72 x 2	95	18	8	3.5	86	3 - M8	18.0
YSR M75 x 2	98	18	8	3.5	90	3 - M8	18.0
YSR M76 x 2	100	18	8	3.5	92	3 - M8	18.0
YSR M80 x 2	105	18	8	3.5	96	3 - M8	18.0
YSR M85 x 2	110	18	8	3.5	102	3 - M8	18.0
YSR M90 x 2	120	20	10	4	108	3 - M8	18.0
YSR M95 x 2	125	20	10	4	113	3 - M8	18.0
YSR M100 x 2	130	20	10	4	118	3 - M8	18.0
YSR M105 x 2	140	22	12	5	125	3 - M8	18.0
YSR M110 x 2	145	22	12	5	132	3 - M8	18.0
YSR M115 x 2	150	22	12	5	137	3 - M8	18.0
YSR M120 x 2	155	24	12	5	142	3 - M8	18.0
YSR M125 x 2	160	24	12	5	147	3 - M8	18.0
YSR M130 x 2	165	24	12	5	152	3 - M8	18.0
YSR M135 x 2	175	26	14	6	160	3 - M10	35.0
YSR M140 x 2	180	26	14	6	165	3 - M10	35.0
YSR M145 x 2	190	26	14	6	175	3 - M10	35.0
YSR M150 x 2	195	26	14	6	180	3 - M10	35.0
YSR M155 x 3	200	28	16	7	180	3 - M10	35.0
YSR M160 x 3	210	28	16	7	190	3 - M10	35.0
YSR M165 x 3	210	28	16	7	190	3 - M10	35.0
YSR M170 x 3	220	28	16	7	200	3 - M10	35.0
YSR M180 x 3	230	30	18	8	205	3 - M12	60.0
YSR M190 x 3	240	30	18	8	215	3 - M12	60.0
YSR M200 x 3	250	32	18	8	225	3 - M12	60.0
YSR-M210 x 3	260	32	18	8	240	3 - M12	60.0
YSR-M220 x 3	270	32	18	8	250	3 - M12	60.0
YSR-M230 x 3	280	34	20	9	258	3 - M12	60.0
YSR-M240 x 3	290	34	20	9	268	3 - M12	60.0
YSR-M250 x 3	300	34	20	9	278	3 - M12	60.0
YSR-M260 x 4	310	34	22	10	288	3 - M14	100.0
YSR-M270 x 4	320	34	22	10	298	3 - M14	100.0
YSR-M280 x 4	330	34	22	10	308	3 - M14	100.0
YSR-M290 x 4	340	36	24	11	315	3 - M14	100.0
YSR-M300 x 4	350	36	24	11	325	3 - M14	100.0