



Features

- Ideal one-body design simple and fast assembly.
- High rigidity high torque.
- Low moment of inertia backlash-free.
- Suitable to small servo system exact transmission.
- With function of flexibility and vibration resistance.
- Long service life maintenance-free.
- Clamp type.
- MHS-C Body : Extra Super Duralumin.

特性

- 一體化設計.安裝簡單
- 高剛性.高扭矩
- 低慣性.無背隙
- 適於中小型伺服馬達精.密定位傳動
- 具伸縮緩衝集抗震功能
- 免保養.壽命長.
- 夾鉗式固定
- MHS-C 本體：鋁合金材質.

Specifications

unit:mm

Product No 產品編號	Rated Torque 常用扭矩 (N.m)	Max. Torque 最大扭矩 (N.m)	Max. Rotational Frequency. 最高迴轉數 (min ⁻¹)	Moment* Of Inertia 慣性 (kg.m ²)	Error of Angularity 容許角偏差 (°)	Error of Shaft End-play 容許軸向位差 (mm)	Mass** 質量 (g)
MHS-27C	1.8	3.6	10000	2.0×10 ⁻⁶	1°	±0.15	25.0
MHS-35C	4.0	8.0	10000	7.5×10 ⁻⁶	1°	±0.2	48.0
MHS-40C	7.0	14.0	10000	20×10 ⁻⁶	1°	±0.25	90.0
MHS-45C	10.0	20.0	10000	28×10 ⁻⁶	1°	±0.3	98.0
MHS-50C	16.0	32.0	10000	68×10 ⁻⁶	1°	±0.35	150.0
MHS-57C	26.0	52.0	10000	105×10 ⁻⁶	1°	±0.4	238.0
MHS-68C	62.0	124.0	10000	313×10 ⁻⁶	1°	±0.45	470.0
MHS-82C	100.0	200.0	10000	830×10 ⁻⁶	1°	±0.6	1050.0
MHS-95C	180.0	360.0	10000	1400×10 ⁻⁶	1°	±0.65	1230.0

*Max. Bore Moment of Inertia/最大孔徑時慣性矩

**Max. Bore Mass/最大孔徑時質量

Clamp type

● MHS-C

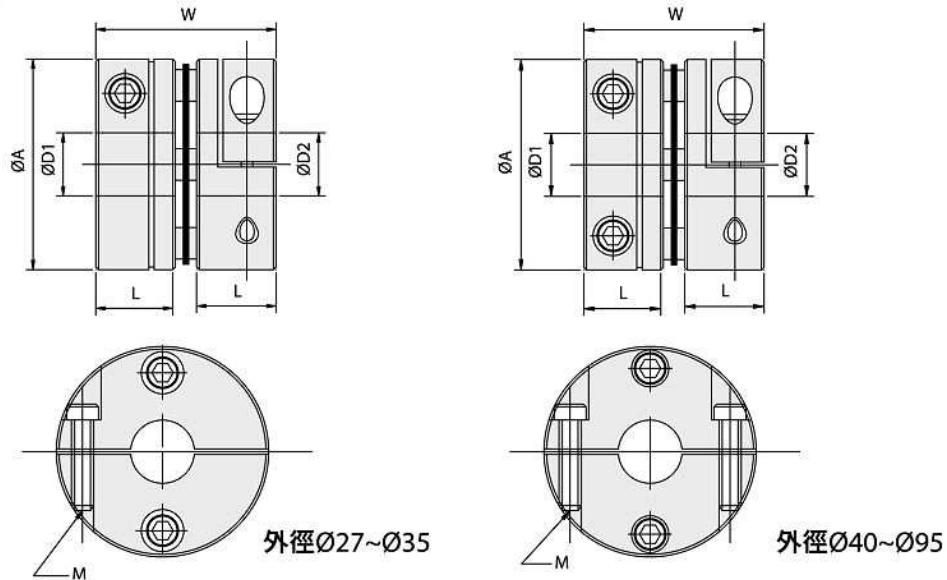

Dimension

unit:mm

Product No 產品編號	A	L	W	Stock Bores 標準孔徑 D1×D2(公差 H8)		M
				Min D1	Max D2	
MHS-27C	27	11	24.5	5	10	M3
MHS-35C	35	12	27	6	14	M3
MHS-40C	40	15	34	8	16	M4
MHS-45C	45	15	34	10	19	M4
MHS-50C	50	20	45	12	22	M5
MHS-57C	57	20	45	12	25	M5
MHS-68C	68	24	54	14	32	M6
MHS-82C	82	30	68	19	35	M8
MHS-95C	95	30	68	22	45	M8

When Ordering

When placing an order, make sure to include product no.
And stock bores(both sides) of product.

MHS-50C - Ø12 X Ø20

Product No D1 D2