

# LMH 切兩側凸緣型 (公制規格)

## Two Side Cut Flange Type (Metric Dimension)

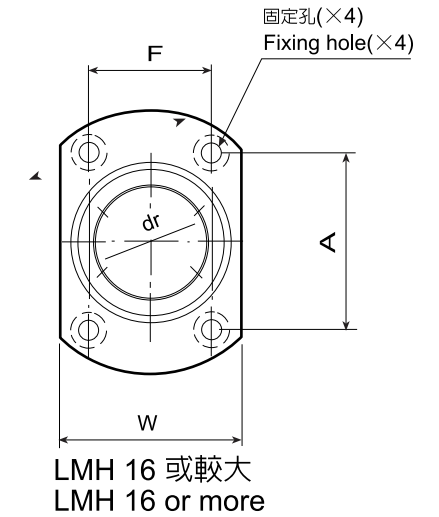
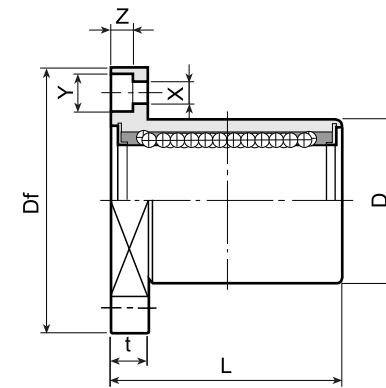
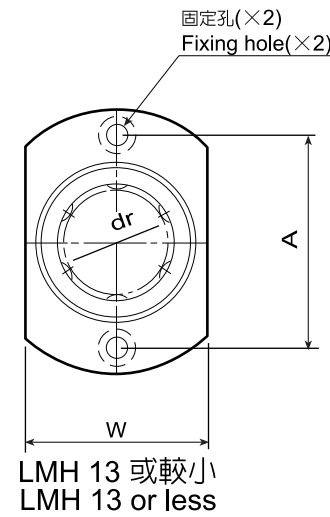
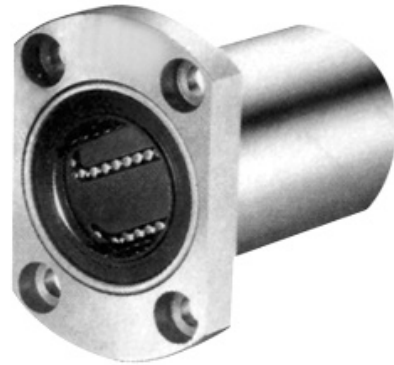

軸徑 Nominal shaft diameter mm	型號 Model No. LMH....UU	主要尺寸及精度 Main dimensions and tolerance						主要尺寸及精度 Main dimensions and tolerance								偏心 Eccentricity μm	直角度 Squareness μm	基本定格荷重 Basic load rating		重量 Weight g	軸徑 Nominal shaft diameter mm
		dr		D		L		凸緣 Flange										動定格 dynamic C(kgf)	靜定格 static Co(kgf)		
		mm	Tolerance 公差 μm	mm	Tolerance 公差 μm	mm	Tolerance 公差 μm	Df mm	W mm	t mm	A mm	F mm	X mm	Y mm	Z mm						
6	LMH 6UU	6		12	0	19	0	28	18	5	20	—	3.5	6	3.1	12	12	21	27	21	6
8	LMH 8UU	8		15	-9	24	-200	32	21	5	24	—	3.5	6	3.1			28	40	33	8
10	LMH 10UU	10	0	19		29		40	25	6	29	—	4.5	7.5	4.1			38	56	64	10
12	LMH 12UU	12	-9	21	0	30		42	27	6	32	—	4.5	7.5	4.1			52	80	68	12
13	LMH 13UU	13		23	-13	32		43	29	6	33	—	4.5	7.5	4.1			52	80	81	13
16	LMH 16UU	16		28		37	-200	48	34	6	31	22	4.5	7.5	4.1			79	120	112	16
20	LMH 20UU	20	0	32	0	42		54	38	8	36	24	5.5	9	5.1	15	15	90	140	167	20
25	LMH 25UU	25	-10	40	-16	59	0	62	46	8	40	32	5.5	9	5.1			100	160	325	25
30	LMH 30UU	30		45		64	-300	74	51	10	49	35	6.6	11	6.1			160	279	388	30