

# LMH-N 切兩側凸緣防銹型(公制規格, 無電解鍍處理)

Two Side Cut Flange Type  
(Metric Dimensions)

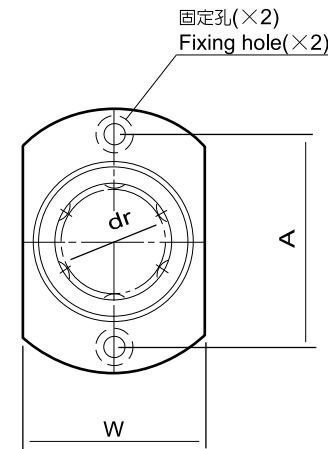

LMH 13-N 或較小  
LMH 13-N or less

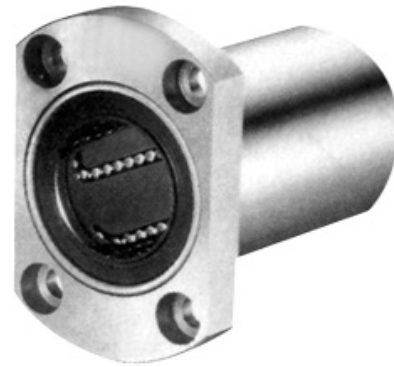
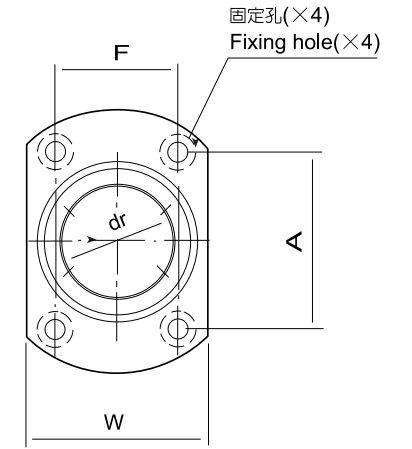
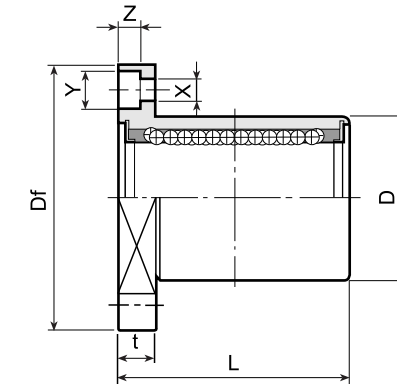

LMH 16-N 或較大  
LMH 16-N or more

軸徑 Nominal shaft diameter mm	型號 Model No. LMH....UU-N	主要尺寸及精度 Main dimensions and tolerance						主要尺寸及精度 Main dimensions and tolerance								偏心 Eccentricity μm	直角度 Squareness μm	基本定格荷重 Basic load rating		重量 Weight g	軸徑 Nominal shaft diameter mm		
		dr		D		L		凸緣 Flange										動定格 dynamic C(kgf)	靜定格 static Co(kgf)				
		mm	Tolerance 公差 μm	mm	Tolerance 公差 μm	mm	Tolerance 公差 μm	Df mm	W mm	t mm	A mm	F mm	X mm	Y mm	Z mm								
6	LMH 6UU-N	6	0	12	0	19	0	28	18	5	20	—	3.5	6	3.1	12	12	21	27	21	6		
8	LMH 8UU-N	8		15	-9	24	-200	32	21	5	24	—	3.5	6	3.1			28	40	33	8		
10	LMH 10UU-N	10		19	0	29	0	40	25	6	29	—	4.5	7.5	4.1			38	56	64	10		
12	LMH 12UU-N	12		21	0	30		42	27	6	32	—	4.5	7.5	4.1			52	80	68	12		
13	LMH 13UU-N	13	-9	23	-13	32	0	43	29	6	33	—	4.5	7.5	4.1	15	15	52	80	81	13		
16	LMH 16UU-N	16		28	-200	37	-200	48	34	6	31	22	4.5	7.5	4.1			79	120	112	16		
20	LMH 20UU-N	20	0	32	0	42	0	54	38	8	36	24	5.5	9	5.1	15	15	90	140	167	20		
25	LMH 25UU-N	25		40		-16		59	0	62	46	8	40	32	5.5			9	5.1	100	160	325	25
30	LMH 30UU-N	30		45		-300		64	-300	74	51	10	49	35	6.6			11	6.1	160	279	388	30