

KH 簡易型

Compact Type

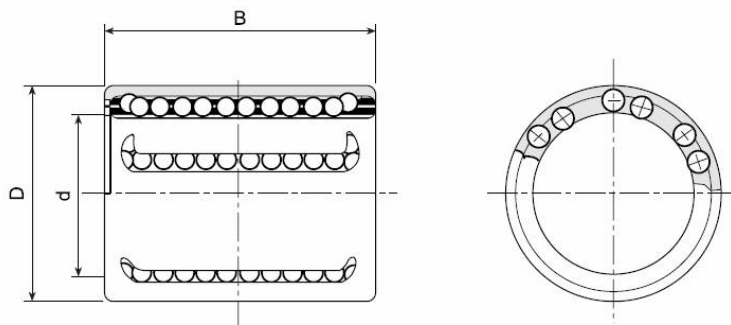

單位(unit) : mm

軸徑 Nominal shaft diameter mm	無油封 No Seal		油封型 Sealed type		主要尺寸 Main dimensions			基本定格荷重 Basic load rating	
	型號 Model No.	重量 Weight g	型號 Model No.	重量 Weight g	d	D	B	動定格 dynamic C(kgf)	靜定格 static Co(kgf)
6	KH0622	7	KH0622PP	7	6	12	22	9	24
8	KH0824	12	KH0824PP	12	8	15	24	11	28
10	KH1026	14	KH1026PP	14.5	10	17	26	14	37
12	KH1228	18	KH1228PP	18.5	12	19	28	18	51
14	KH1428	20.5	KH1428PP	21	14	21	28	19	52
16	KH1630	27	KH1630PP	27.5	16	24	30	24	62
20	KH2030	32.5	KH2030PP	33	20	28	30	28	79
25	KH2540	61.5	KH2540PP	63	25	35	40	65	167
30	KH3050	90	KH3050PP	92	30	40	50	100	270
40	KH4060	182	KH4060PP	184	40	52	60	170	445
50	KH5070	250	KH5070PP	255	50	62	70	235	630