

線性滑軌標準斜楔



一、基本尺寸

UNIT : mm

TYPE	A	B	C	D	E	F	M
T-1 S	20	10	16	7	9.4	11.7	M6×P1.0 螺孔
T-1	20	10	16	7	9.4	11.7	$\phi 5.5 \times \phi 9.5 \times 5.4$
T-2	25	12.5	20	8	10.5	15.1	$\phi 6.6 \times \phi 11 \times 6.5$
T-3	30	15	24	9	13.6	17.3	$\phi 9 \times \phi 14 \times 8.6$

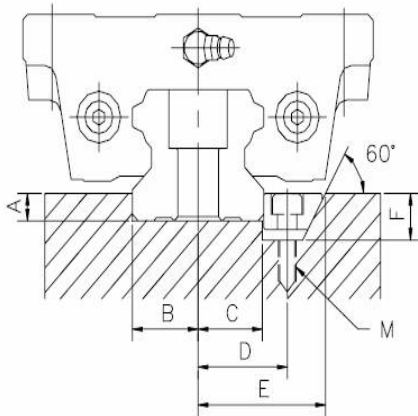
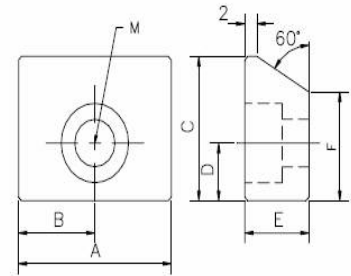

推薦扭緊力矩

kgf-cm

螺栓	扭緊力矩
M5	90
M6	140
M8	310

UNIT : mm

TYPE	A	B	C	D	E	F	M	S	SCREW
HSR 20	3	10	9.5	17	27.155	12.4	M5	T-1	M5
HSR 25	4	11.5	11	18.5	28.655	12.4	M5	T-1	M5
HSR 30	5	14	13.5	21	31.155	12.4	M5	T-1	M5
HSR 35	5	17	16.5	25	38.155	13.5	M6	T-2	M6
HSR 45	7	22.5	22	30.5	43.655	13.5	M6	T-2	M6
HSR 55	10	26.5	26	35.5	51.655	16.6	M8	T-3	M8
HSR 65	10	31.5	31	40.5	56.655	16.6	M8	T-3	M8