

G
▽ (▽▽)

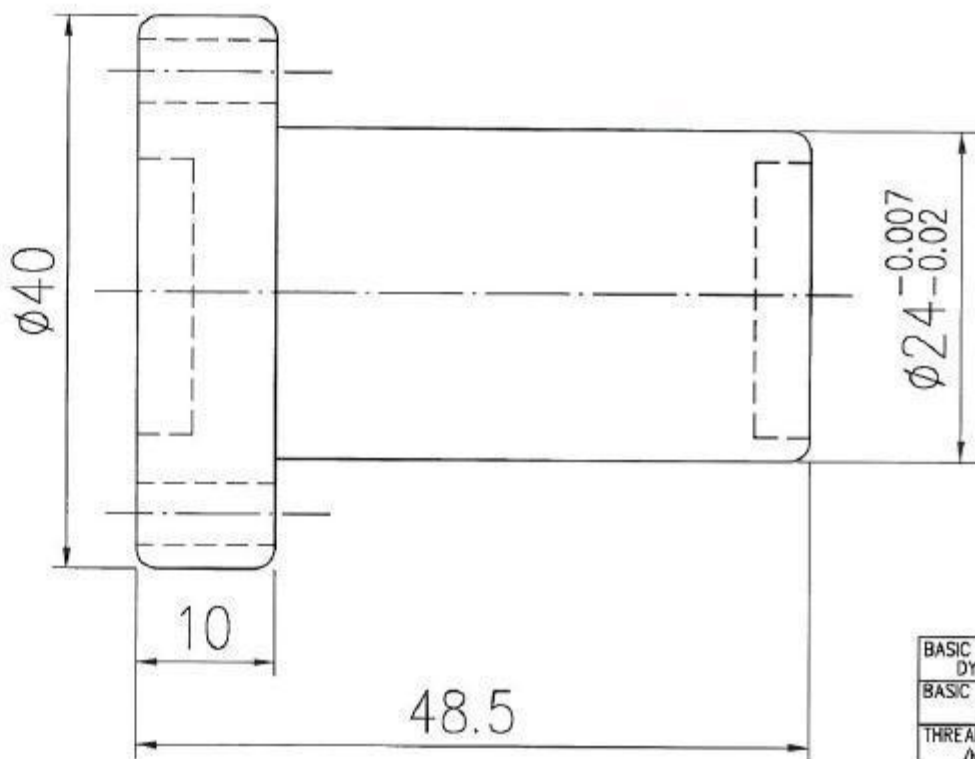
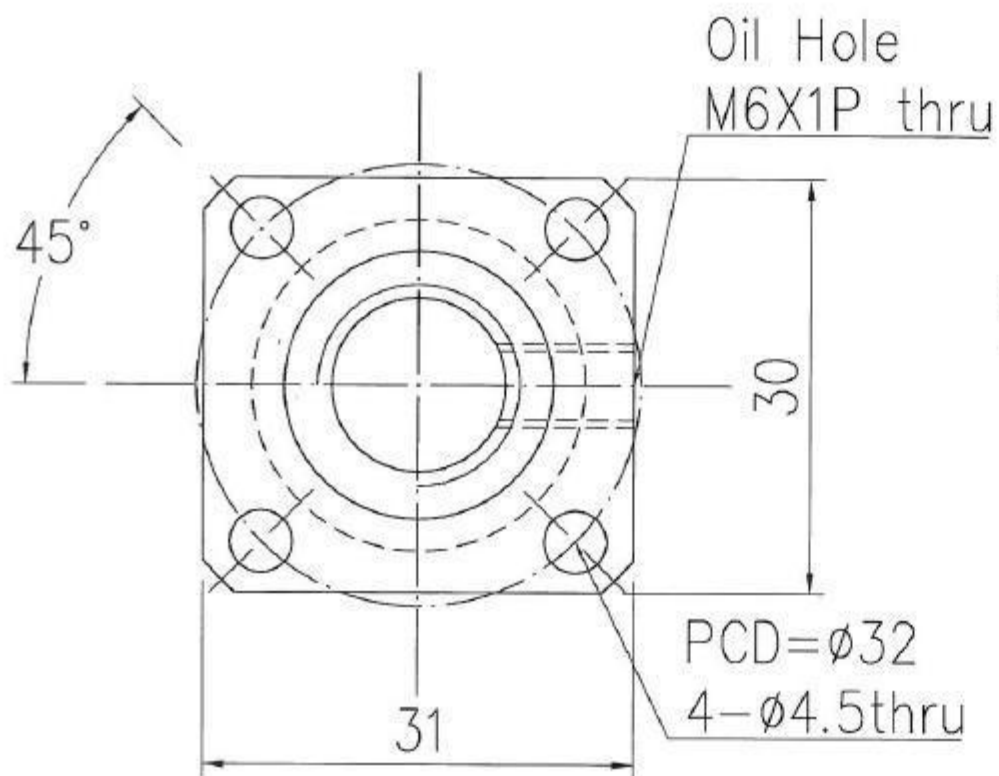

BASIC RATED DYNAMIC LOAD (kgf)	552
BASIC RATED STATIC LOAD(kgf)	698
THREAD DIR. /NO. OF START THD	RIGHT/ 1
BCD (mm)	φ12
LEAD (mm)	10
BALL DIA.(mm)	φ2
ROOT DIA.	φ14
EFFECTIVE TURNS (CIRCUITxROW)	3
LEAD ANGLE	14.86°

Ball Nut Dwg NO

TOLERANCES FOR REGULAR DIMENSIONS (MM)				SURFACE ROUGHNESS Ra(μm)
RANGE	TOLERANCE	RANGE	TOLERANCE	
0.5-6	±0.1	401-1000	±0.8	▽ FINE FINISH 6.3a
7-30	±0.2	1001-2000	±1.2	
31-120	±0.3	2001-4000	±2.0	G GRIND FINISH 1.6a
121-400	±0.5	4001 OVER	±3.0	

CUSTOMER:

SPEC=R12-10T3-XSCD

(註：未標之倒角皆為C0.5)

Note: Chamferings are C0.5 if not specified otherwise

NOT EFFECTIVE HARDENED AREA (不在有效熱處理範圍內)

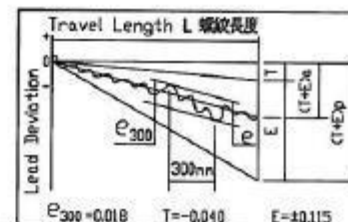

AXIAL PLAY		
DRAG	CENTER	0
TORQUE RANGE 0		
(kgf-cm)	SPRING FORCE (kgf)	0
THREAD PROFILE GOTHC		

Accessory	QTY	Accessory	QTY
循環器	2		
刮刷器	2		

DRAW	
CHECK	
APPROVE	
DATE	102-05-13



GTEN BALL SCREW TECHNOLOGY

DWG NO.

CUSTOMER'S DWG. NO.



SCALE 1:X

MATERIAL	SCREW	S55C
材質	NUT	SCM415H
HARDNESS	SCREW	滾珠牙部 HRC58°-62°
熱處理	NUT	滾珠牙部 HRC58°-62°