

7.5 Type: FSC

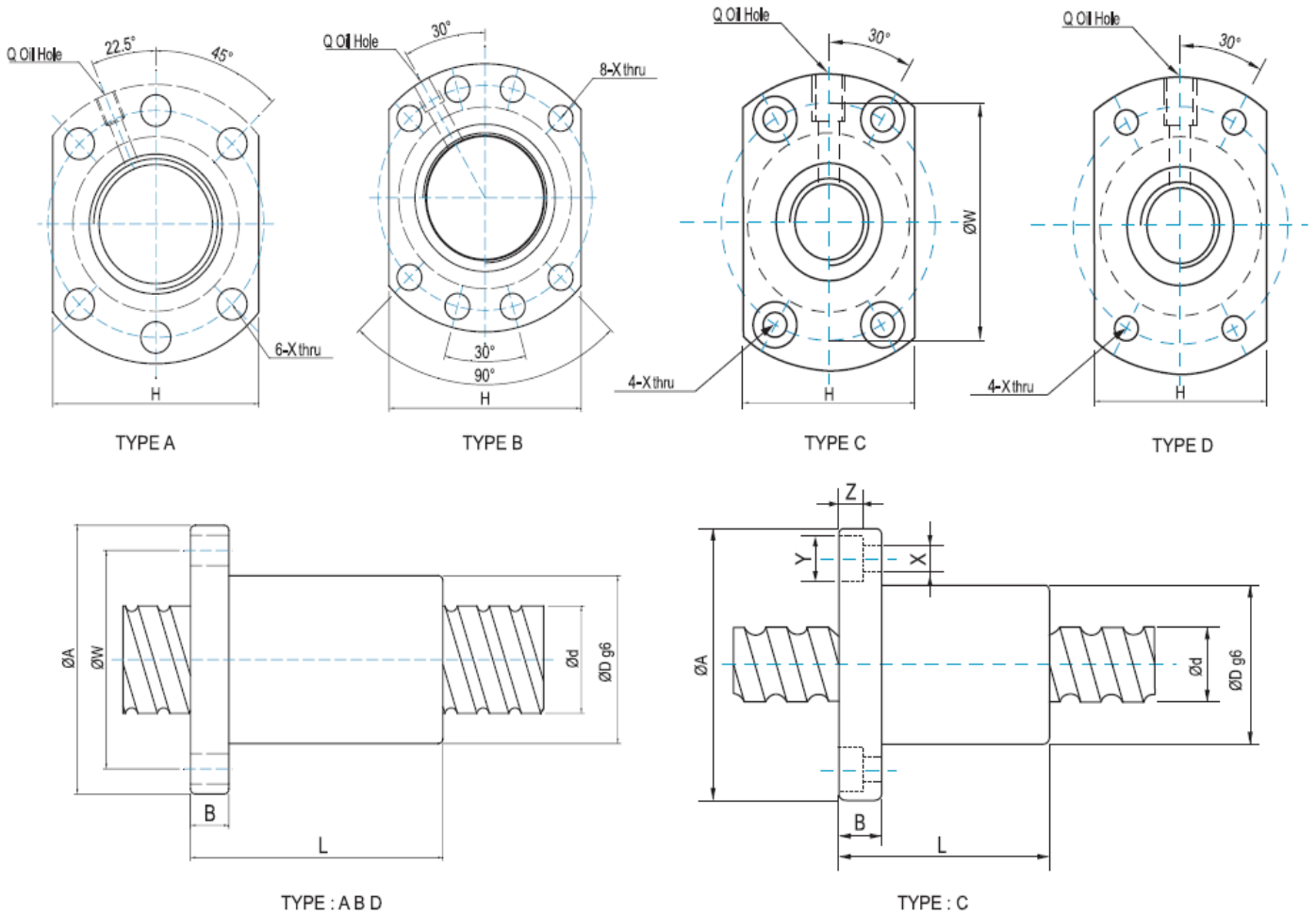

Unit : mm

Model No.	Dimensions												Type	H	Q	n	Ca(Kgf)	Coa(kgf)
	d	I	Da	D	A	B	L	W	X	Y	Z							
1210-2	12	10	2	30	50	10	40	40	4.5	8	4.5	C	32	M6	T2	390	466	
1520-2	15	20	3.175	34	55	12	57	45	6	-	-	D	34	M6	T2	833	997	
1610-3	16	10	3.175	28	48	12	43	38	5.5	-	-	A	40	M6	T3	1180	1496	
1616-3	16	16	3.175	28	48	12	61	38	5.5	-	-	A	40	M6	T3	1180	1496	
2010-2	20	10	3.969	46	74	13	54	59	6.6	11	5.5	C	46	M6	T2	1246	1559	
2020-4	20	20	3.175	36	58	10	55	47	6.6	-	-	A	44	M6	T4	1659	2464	
▲ 2510-4	25	10	3.5	40	62	12	64	51	6.6	-	-	A	48	M6	T4	2067	3280	
2525-4	25	25	3.969	47	74	12	67	60	6.6	-	-	A	56	M6	T4	2481	3851	
3220-3	32	20	3.969	50	80	13	78	65	9	-	-	A	62	M6	T3	2141	3576	
3232-4	32	32	4.762	56	86	16	82	71	9	-	-	A	65	M6	T4	3585	6071	
4020-3	40	20	5.556	63	93	15	83	78	9	-	-	B	70	M8	T3	3782	6468	
4040-4	40	40	6.35	65	95	18	100	80	9	-	-	B	72	M8	T4	5778	11753	
5020-5	50	20	6.35	75	110	18	121	93	11	-	-	B	85	M8	T5	7737	18189	

▲ steel balls 3.5mm, please order 3.5mm shaft to meet