

7.4 Type: FDI

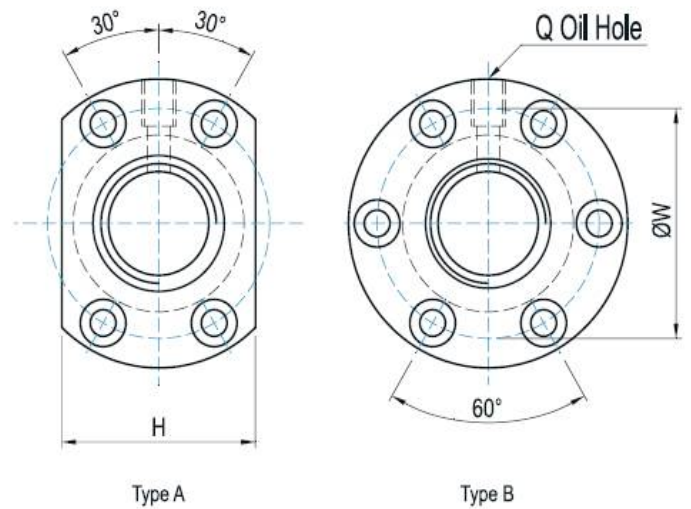
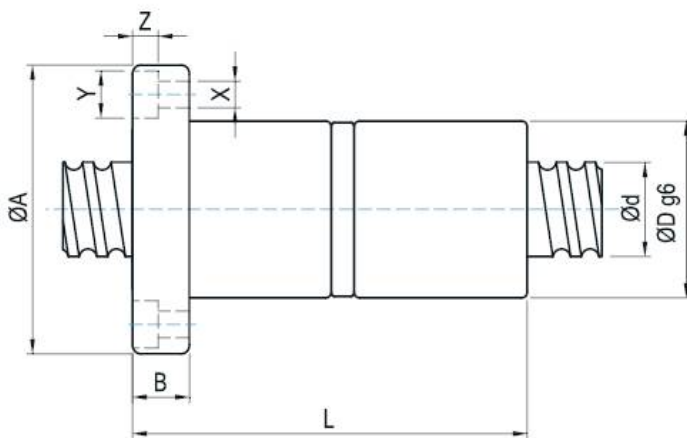

單位：mm

型號	規格																
	d	I	Da	D	A	B	L	W	X	Y	Z	Type	H	Q	n	Ca(Kgf)	Coa(kgf)
★ 1605-3	16	5	3.175	30	49	10	80	39	4.5	8	4.5	A	34	M6	T3	1049	1144
★ 2005-4	20	5	3.175	34	57	12	92	45	5.5	9.5	5.5	A	40	M6	T4	1512	1995
★ 2505-4	25	5	3.175	40	63	12	92	51	5.5	9.5	5.5	A	46	M8	T4	1704	2581
2510-4	25	10	4.762	46	72	12	156	58	6.5	11	6.5	A	52	M6	T4	2881	3695
★ 3205-4	32	5	3.175	46	72	12	92	58	6.5	11	6.5	A	52	M8	T4	1924	3403
3210-4	32	10	6.35	54	88	16	160	70	9	14	8.5	A	62	M8	T4	4834	7835
★ 4005-4	40	5	3.175	56	90	16	96	72	9	14	8.5	A	64	M8	T4	2142	4342
4010-4	40	10	6.35	62	104	18	162	82	11	17.5	11	A	70	M8	T4	5399	10074
5010-4	50	10	6.35	72	114	18	162	92	11	17.5	11	A	82	M8	T4	5933	12313
6310-4	63	10	6.35	85	131	22	182	107	14	20	13	B	-	M8	T4	6700	16230
6320-3	63	20	9.525	95	153	23	253	123	18	26	17.5	B	-	M8	T3	8957	17945
8010-4	80	10	6.35	105	150	22	182	127	14	20	13	B	-	M8	T4	7547	21268
8020-3	80	20	9.525	115	173	23	253	143	18	26	17.5	B	-	M8	T3	10168	23611

★可生產左牙